



THANK YOU FOR BUYING A WHIRLPOOL PRODUCT
In order to receive a more complete assistance, please register your product on www.whirlpool.eu/register



Before using the appliance carefully read the Safety Instruction.

PRODUCT DESCRIPTION

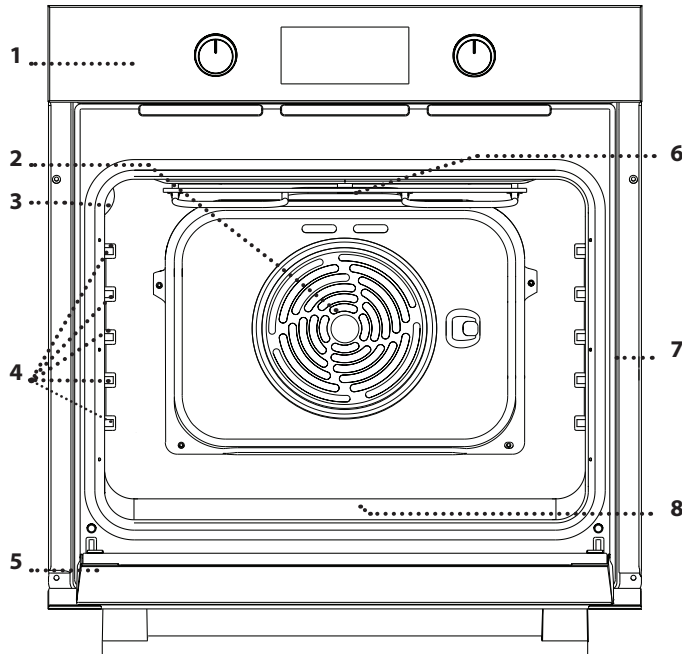

1. Control panel
2. Fan and circular heating element (not visible)
3. Lamp
4. Shelf guides (the level is indicated on the wall of the cooking compartment)
5. Door
6. Top heating element/grill
7. Identification plate (do not remove)
8. **STEAM** embossing for drinking water

CONTROL PANEL DESCRIPTION

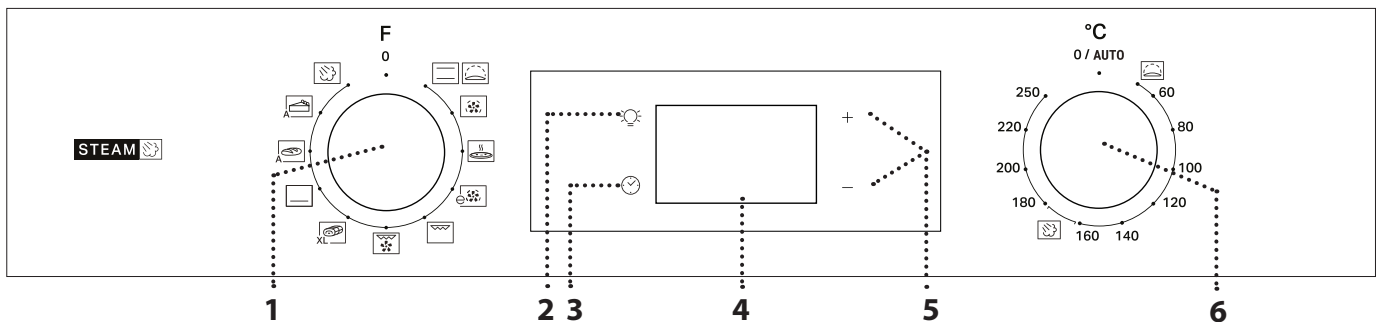

1. SELECTION KNOB

For switching the oven on by selecting a function.
Turn to the 0 position to switch the oven off.

2. LIGHT

With the oven switched on, press  to turn the oven compartment lamp on or off.

3. SETTING THE TIME

For accessing the cooking time settings, delayed start and timer.
For displaying the time when the oven is off.

4. DISPLAY

5. ADJUSTMENT BUTTONS

For changing the cooking time settings.

6. THERMOSTAT KNOB

Turn to select the temperature you require when activating manual functions.

Please note: Type of knob may vary from model type. If the knobs are push-activated, push down on the center of the knob to release it from seating.

ACCESSORIES

WIRE SHELF

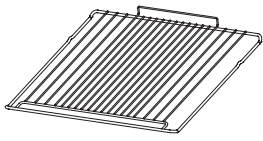

Use to cook food or as a support for pans, cake tins and other ovenproof items of cookware.

DRIP TRAY *

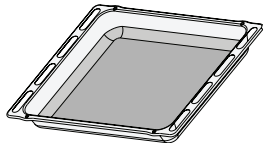

Use as an oven tray for cooking meat, fish, vegetables, focaccia, etc. or position underneath the wire shelf to collect cooking juices.

BAKING TRAY *

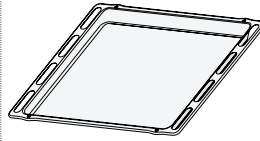

Use for cooking all bread and pastry products, but also for roasts, fish en papillote, etc.

SLIDING RUNNERS *

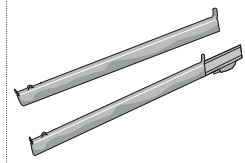

To facilitate inserting or removing accessories.

* Available only on certain models

The number and the type of accessories may vary depending on which model is purchased. Other accessories can be purchased separately from the After-sales Service.

INSERTING THE WIRE SHELF AND OTHER ACCESSORIES

Insert the wire shelf onto the level you require by holding it tilted slightly upwards and resting the raised rear side (pointing upwards) down first.

SLIDING RUNNERS AND SHELF GUIDES

Before using the oven remove the protective tape [a] and then remove the protective foil [b] from the sliding runners.

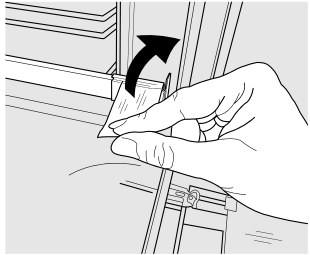

[a]

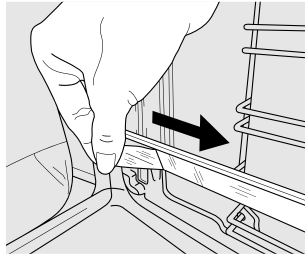

[b]

REMOVING THE SLIDING RUNNERS [c]

Pull the lower part of the sliding runner to uncouple the lower hooks (1) and pull the sliding runners upwards, removing them from the upper hooks (2).

REFITTING THE SLIDING RUNNERS [d]

Hook the upper hooks on the shelf guides (1) then press the lower part of the sliding runners against the shelf guides, until the lower hooks are clicking (2).

FIRST TIME USE

1. SETTING THE TIME

You will need to set the time when you switch on the appliance for the first time: Press until the icon and the two digits for the hour start flashing on the display.



Use + or - to set the hour and press to confirm. The two digits for the minutes will start flashing. Use + or - to set the minutes and press to confirm. Please note: When the icon is flashing, for example following lengthy power outages, you will need to reset the time.

Then slide it horizontally along the runners as far as possible.

Other accessories, like the baking tray, are to be inserted horizontally, letting them slide on the runners.

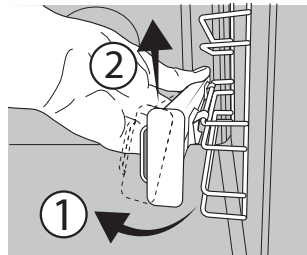

[c]

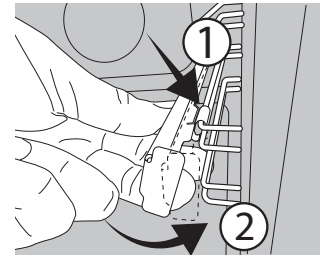

[d]

REMOVING AND REFITTING THE SHELF GUIDES

1. To remove the shelf guides, firmly grip the external part of the guide, and pull it towards you to extract the support and the two internal pins from the lodging.

2. To reposition the shelf guides, position them near the cavity and initially insert the two pins into their lodgings. Next, position the external part near its lodging, insert the support, and firmly press towards the wall of the cavity to make sure the shelf guide is properly secured.

2. HEAT THE OVEN

A new oven may release odours that have been left behind during manufacturing: this is completely normal. Before starting to cook food, we therefore recommend heating the oven with it empty in order to remove any possible odours.

Remove any protective cardboard or transparent film from the oven and remove any accessories from inside it.

Heat the oven to 250 °C for about one hour. The oven must be empty during this time.

Please note: It is advisable to air the room after using the appliance for the first time.

FUNCTIONS



CONVENTIONAL

For cooking any kind of dish on one shelf only.



RISING

For helping sweet or savoury dough to rise effectively. Turn the thermostat knob to the icon to activate this function.



FORCED AIR

For cooking different foods that require the same cooking temperature on several shelves (maximum three) at the same time. This function can be used to cook different foods without odours being transferred from one food to another.



PIZZA

For baking different types and sizes of pizza and bread. It is a good idea to swap the position of the baking trays halfway through cooking.



ECO FORCED AIR

For cooking roasts and stuffed roasting joints on a single shelf. Food is prevented from drying out excessively by gentle, intermittent air circulation. When this ECO function is in use, the light will remain switched off during cooking but can be switched on again by pressing .



GRILL

For grilling steaks, kebabs and sausages, cooking vegetables au gratin or toasting bread. When grilling meat, we recommend using a dripping pan to collect the cooking juices: position the pan on any of the levels below the wire shelf and add 200 ml of drinking water.



TURBO GRILL

For roasting large joints of meat (legs, roast beef, chicken). We recommend using a dripping pan to collect the cooking juices: position the pan on any of the levels below the wire shelf and add 200 ml of drinking water.



MAXI COOKING

For cooking large joints of meat (above 2.5kg). We recommend turning the meat over during cooking to ensure that both sides brown evenly. We also recommend basting the joint every so often to prevent it from drying out excessively.



BOTTOM HEATING

Useful for browning the bottom of dishes. Function also recommended for slow cooking, to finish cooking dishes with a very liquid consistency or concentrate sauces and gravies.



BREAD AUTO

This function automatically selects the ideal temperature and baking time for bread. For best results, carefully follow the recipe. Activate the function when the oven is cold. Thermostat knob needs to remain in **0 / AUTO** position as the temperature is set automatically by the function.



PASTRY AUTO

This function automatically selects the ideal temperature and baking time for cakes. Activate the function when the oven is cold. Thermostat knob needs to remain in **0 / AUTO** position as the temperature is set automatically by the function.



STEAM+

The Steam+ function allows to obtain excellent performances thanks to the presence of steam in the cooking cycle. This function automatically manages the ideal temperature for cooking a wide range of recipes; the cooking times of the main dishes are shown in the relative cooking table. Always activate the steam function when the oven is cold, and after pouring 200 ml of drinking water into the bottom of the cavity. To activate Steam+ function, the thermostat knob needs to be turned in to position of  icon.

DAILY USE

1. SELECT A FUNCTION

To select a function, turn the *selection knob* to the symbol for the function you require: the display will light up and an audible signal will sound.



2. ACTIVATE A FUNCTION

MANUAL

To start the function you have selected, turn the *thermostat knob* to set the temperature you require.



Please note: During cooking you can change the function by turning the selection knob or adjust the temperature by turning the thermostat knob. The function will not start if the thermostat knob will be on **0 / AUTO** position. You can set the cooking time, cooking end time (only if you set a cooking time) and a timer.

RISING

To start the "Rising" function, turn the *thermostat knob* to Rising position (40 deg) and put function knob in Conventional position; if the oven is set to a different temperature, the function will not start. Please note: You can set the cooking time, cooking end time (only if you set a cooking time) and a timer.

STEAM

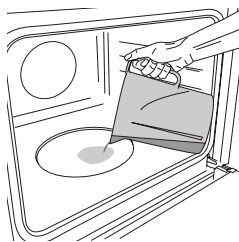

To start the Steam function, pour 200 ml of drinking water in the oven bottom. Select the function turning clockwise the selection knob on the relevant icon, and the thermostat knob in any position between 160 and 180°C (as suggested by the icon). The function will start and the display will show the current time of the day. No preheating is needed. To end the cooking, turn the selection knob on **0** position. During Steam cooking do not open the door and never top up the water.

Please note: To set a specific duration, according to the related cooking table, follow the instruction in the "Programming Cooking" paragraph.

3. PREHEATING AND RESIDUAL HEAT

Once the function starts, an audible signal and a flashing icon  on the display indicate that the preheating phase is active.

When the set temperature has been reached, the icon becomes fixed and a new audible signal will sound to indicate that the food can be placed inside and cooking can proceed.

Please note: Placing food in the oven before the preheating phase has finished may have an adverse effect on the final result of cooking.



After cooking and with the function deactivated, the icon  may continue to remain visible on the display even after the cooling fan has switched off to indicate that there is residual heat in the compartment.

Please note: The time after which the icon switches off varies because it depends on a series of factors such as ambient temperature and function used. In any case, the product should be considered to be off when the pointer on the selection knob is at "0".

4. PROGRAMMING COOKING

You will need to select a function before you can start programming cooking.



DURATION

Keep pressing  until the  icon and "00:00" start flashing on the display.



Use + or - to set the cooking time you require, then press  to confirm.

Activate the function by turning the *thermostat knob* to the temperature you require: an audible signal will sound and the display will indicate that cooking is complete.

Please note: To cancel the cooking time you have set, keep pressing  until the  icon starts flashing on the display, then use - to reset the cooking time to "00:00". This cooking time includes a preheating phase.

PROGRAMMING THE END COOKING TIME/ DELAYED START

After a cooking duration has been set, starting the function can be delayed by programming its end time: press  until the  icon and the current time start flashing on the display.



Use + or - to set the time you want cooking to end and press  to confirm.

Activate the function by turning the *thermostat knob* to the temperature you require: the function will remain paused until it starts automatically after the period of time that has been calculated in order for cooking to finish at the time you have set.

Please note: To cancel the setting, switch the oven off by turning the selection knob to the 0 position.

END OF COOKING

An audible signal will sound and the display will indicate that the function has finished.





Turn the *selection knob* to select a different function or to 0 to switch the oven off.

Please note: If the timer is active, the display will show "END" alternately with the remaining time.

5. SETTING THE TIMER

This option does not interrupt or program cooking but allows you to use the display as a timer, either during while a function is active or when the oven is off.

Keep pressing  until the  icon and "00:00" start flashing on the display.



Use + or - to set the time you require and press  to confirm.

An audible signal will sound once the timer has finished counting down the selected time.

Notes: To cancel the timer, keep pressing  until the  icon starts flashing, then use - to reset the time to "00:00".

COOKING TABLE

RECIPE	FUNCTION	PREHEAT	TEMPERATURE (°C)	DURATION (Min)	LEVEL AND ACCESSORIES
Leavened cakes		Yes	170	30 - 50	
		Yes	160	30 - 50	
		Yes	160	40 - 60	
Filled cake (cheese cake, strudel, fruit pie)		Yes	160 - 200	35 - 90	
		Yes	160 - 200	40 - 90	
Biscuits / tartlets		Yes	160	25 - 35	
		Yes	160	25 - 35	
		Yes	150	35 - 45	
Choux buns		Yes	180 - 210	30 - 40	
		Yes	180 - 200	35 - 45	
		Yes	180 - 200	35 - 45	
Meringues		Yes	90	150 - 200	
		Yes	90	140 - 200	
		Yes	90	140 - 200	
Pizza / Focaccia		Yes	190 - 250	15 - 50	
		Yes	190 - 250	20 - 50	
Frozen pizza		Yes	250	10 - 20	
		Yes	230-250	10 - 25	
Salty cakes (vegetable pie, quiche)		Yes	180 - 200	40 - 55	
		Yes	180 - 200	45 - 60	
		Yes	180 - 200	45 - 60	
Vols-au-vents / puff pastry crackers		Yes	190 - 200	20 - 30	
		Yes	180 - 190	20 - 40	
		Yes	180 - 190	20 - 40	
Lasagne / baked pasta / cannelloni / flans		Yes	190 - 200	45 - 65	
Lamb / veal / beef / 1 kg		Yes	190 - 200	80 - 110	
Roast with crackling 2 kg		Yes	180 - 190	110 - 150	
Chicken / rabbit / duck 1 kg		Yes	200 - 230	50 - 100	
Turkey / goose 3 kg		-	190 - 200	100 - 160	
Baked fish / en papillote (fillets, whole)		Yes	170 - 190	30 - 45	
Stuffed vegetables (tomatoes, courgettes, aubergines)		Yes	180 - 200	50 - 70	
Toasted bread		5'	250	2 - 6	
Fish fillets / slices		-	230 - 250	15 - 30 *	

ACCESSORIES					
	Wire shelf	Baking dish on the wire shelf	Baking tray/Drip tray or baking dish on the wire shelf	Drip tray / Baking tray	Drip tray / Baking tray with 200 ml of water

FUNCTIONS							
	Conventional	Forced air	Pizza	Maxi cooking	Grill	Turbo grill	Eco forced air

RECIPE	FUNCTION	PREHEAT	TEMPERATURE (°C)	DURATION (Min)	LEVEL AND ACCESSORIES
Sausages / kebabs / spare ribs / hamburgers		-	250	15 - 30 *	5 4
Roast chicken 1-1,3 kg		Yes	200 - 220	55 - 70 **	2 1
Roast beef rare 1 kg		Yes	200 - 210	35 - 50 **	3
Leg of lamb / knuckle		Yes	200 - 210	60 - 90 **	3
Roast potatoes		Yes	200 - 210	35 - 55	2
Vegetable gratin		-	200 - 210	25 - 55	3
Meat and potatoes		Yes	190 - 200	45 - 100 ***	4 1
Fish and vegetables		Yes	180	30 - 50 ***	4 2
Lasagne and meat		Yes	200	50 - 100 ***	4 1
Complete meal: fruit tart (level 5) / lasagne (level 3) / meat (level 1)		Yes	180 - 190	40 - 120 ***	5 3 1
Roast meat / stuffed roasting joints		-	170 - 180	100 - 150	3

* Turn food halfway through cooking

** Turn food two thirds of the way through cooking (if necessary).

*** Estimated length of time: dishes can be removed from the oven at different times depending on personal preference.



COOKING TABLE STEAM+

FOOD	RECIPE	QUANTITY	TIME (min)	ACCESSORIES	LEVEL	WATER
 BREAD	Small breads	80-100 g	30 - 45		2	 200 ml
	Sandwich loaf in tin	300-500 g	40 - 60			
	Bread	500g-2 kg	50 - 100			
	Baguettes	200-300 g	30 - 45			
 MEAT	Roast	1 kg	60 - 110			
	Ribs	500g-1,5 kg	50 - 75			
	Chicken	1-1,5 kg	55 - 80			
	Chicken/Turkey	3 kg	100 - 140			
 FISH	Fillet Steak	0.5-2 cm	15 - 25			
	Fillet Steak	2-4 cm	20 - 35			
	Whole Fish	300- 600 g	20 - 30			
	Whole Fish	600 -1200 g	25 - 45			
 VEGETABLES	Steamed Potatoes	0.5-1.5 kg	45 - 60			
	Stuffed Peppers	1-2 kg	35 - 55			
	Steamed Broccoli	0.3-1 kg	30 - 50			
	Steamed Zucchini	0.5-1.5 kg	30 - 50			
 PASTRIES	Cookies	a tray	25 - 35			
	Muffin	30-60 g	25 - 45			
	Sponge Cake	500-700 g	30 - 50			
	Tart	a tin	35 - 55			

Start the STEAM+ function only when the oven is cold. Opening the door and topping up the water during cooking may have an adverse effect on the final cooking result.

ACCESSORIES	 Wire shelf	 Baking dish on the wire shelf	 Baking tray/Drip tray or baking dish on the wire shelf	 Drip tray / Baking tray	 Drip tray / Baking tray with 200 ml of water		
FUNCTIONS	 Conventional	 Forced air	 Pizza	 Maxi cooking	 Grill	 Turbo grill	 Eco forced air

CLEANING AND MAINTENANCE

Make sure that the oven has cooled down before carrying out any maintenance or cleaning.

Do not use steam cleaners.

Do not use wire wool, abrasive scourers or abrasive/corrosive cleaning agents, as these could damage the surfaces of the appliance.

Wear protective gloves.

The oven must be disconnected from the mains before carrying out any kind of maintenance work.

EXTERIOR SURFACES

Clean the surfaces with a damp microfibre cloth. If they are very dirty, add a few drops of pH-neutral detergent. Finish off with a dry cloth. Do not use corrosive or abrasive detergents. If any of these products inadvertently comes into contact with the surfaces of the appliance, clean immediately with a damp microfibre cloth.

INTERIOR SURFACES

• After every use, leave the oven to cool and then clean it, preferably while it is still warm, to remove any deposits or stains caused by food residues. To dry any condensation that has formed as a result of cooking foods with a high water content, leave the oven to cool completely and then wipe it with a cloth or sponge.

• To remove the remaining limescale from the bottom of the cavity after **STEAM** cooking, we recommend to clean the cavity with the products provided by After Sales Service (please follow instructions attached to the product).

Cleaning is recommended at least every 5 to 10 **STEAM** cooking cycles.

- The door can be easily removed and refitted to facilitate cleaning of the glass
- Clean the glass in the door with a suitable liquid detergent.

ACCESSORIES

Soak the accessories in a washing-up liquid solution after use, handling them with oven gloves if they are still hot. Food residues can be removed using a washing-up brush or a sponge.

CLEANING THE CATALYTIC PANELS (ONLY IN SOME MODELS)

This oven could be equipped with special catalytic liners that facilitate cleaning of the cooking compartment thanks to their special self-cleaning coating, which is highly porous and able to absorb grease and grime. These panels are fitted to the shelf guides: When repositioning and then refitting the shelf guides, make sure that the hooks at the top are slotted into the appropriate holes in the panels.

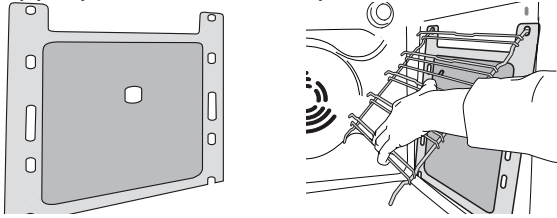

To make best use of the catalytic panels' self-cleaning properties, we recommend heating the oven to 200 °C for around one hour using the "Convection Bake" function. The oven must be empty during this time. Then leave the oven to cool down before removing any remaining food residues using a non-abrasive sponge.

Please note: Using corrosive or abrasive cleaning agents, stiff brushes, pan scourers or oven sprays could damage the catalytic surface and compromise its self-cleaning properties. Please contact our After-sales Service if you require replacement panels.

REMOVING AND REFITTING THE DOOR

1. To remove the door, open it fully and lower the catches until they are in the unlock position.

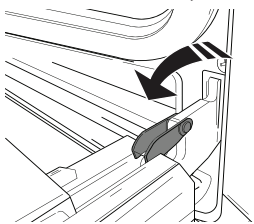

2. Close the door as much as you can. Take a firm hold of the door with both hands – do not hold it by the handle.

Simply remove the door by continuing to close it while pulling it upwards (a) at the same time until it is released from its seating (b).

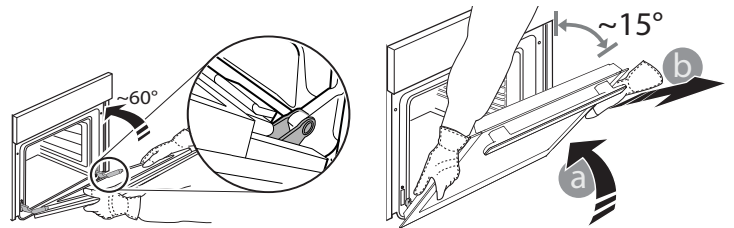

Put the door to one side, resting it on a soft surface.

3. Refit the door by moving it towards the oven, aligning the hooks of the hinges with their seating and securing the upper part onto its seating.

4. Lower the door and then open it fully. Lower the catches into their original position: make sure that you lower them down completely.

5. Try closing the door and check to make sure that it lines up with the control panel. If it does not, repeat the steps above.

REPLACING THE LAMP

1. Disconnect the oven from the power supply.
2. Unscrew the cover from the light, replace the bulb and screw the cover back on the light.
3. Reconnect the oven to the power supply.

Please note: Use 25 W/230 V type G9, T300 °C halogen lamps. The bulb used in the product is specifically designed for domestic appliances and is not suitable for general room lighting within the home (EC Regulation 244/2009). Light bulbs are available from our After-sales Service. - Do not handle bulbs with your bare hands as your fingerprints could damage them. Do not use the oven until the light cover has been refitted.

CLEANING OF THE DOOR GLASSES

1. After removing the door and resting it on a soft surface with the handle downwards, simultaneously press the two retaining clips and remove the upper edge of the door by pulling it towards you.

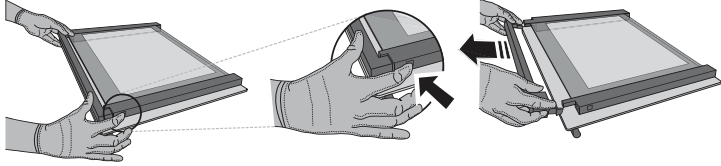

2. Lift and firmly hold the inner glass with both hands, remove it and place it on a soft surface before cleaning it.

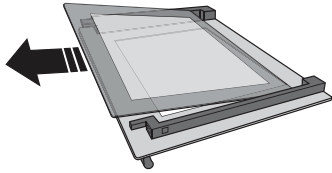

3. Refit the intermediate pane (marked with "R") before refitting the inside pane: To position the panes of glass correctly, make sure that the "R" mark can be seen in the left-hand corner. First insert the long side of the glass marked "R" into the support seats, then lower it into position. Repeat this procedure for both panes of glass.

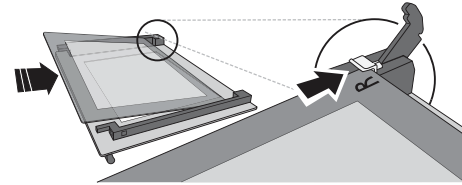

4. Refit the upper edge: A click will indicate correct positioning. Make sure the seal is secure before refitting the door.

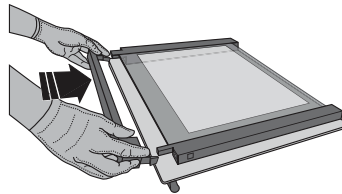

TROUBLESHOOTING

Problem	Possible cause	Solution
The oven is not working.	Power cut. Disconnection from the mains.	Check for the presence of mains electrical power and whether the oven is connected to the electricity supply. Turn off the oven and restart it to see if the fault persists.
The display shows the letter "F" followed by a number or letter.	Oven failure.	Contact you nearest Client After-sales Service Centre and state the number following the letter "F".
The display is showing the message "Hot" and the selected function will not start.	Temperature too high.	Allow the oven to cool down before activating the function. Select a different function.
The display shows unclear text and appears to be broken.	Another language set.	Contact your nearest Client After-sales Service Center.



Policies, standard documentation and additional product information can be found by:

- Visiting our website docs.whirlpool.eu
- Using QR Code
- Alternatively, **contact our After-sales Service** (See phone number in the warranty booklet). When contacting our After-sales Service, please state the codes provided on your product's identification plate.

